

SFR - industry relay

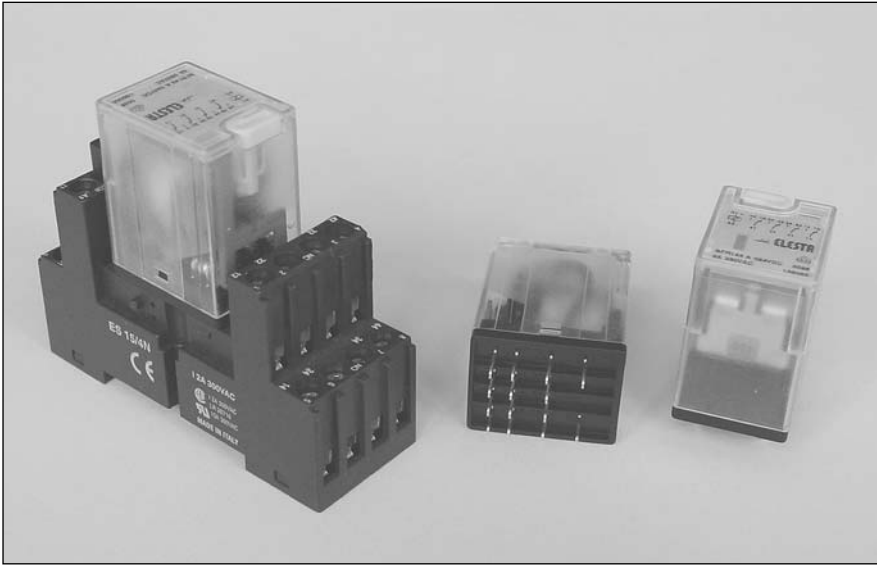

the SFR-industry relay

SFR industry relays are the ideal relays for control systems.

A simple construction guarantees the safety of these relays. The large contact rivet (\varnothing 3 mm) guarantees the extraordinary life time.

An ideal product for control systems in combination with the socket program and the accessories.

features

- large contacts (\varnothing 3 mm)
- extraordinary life time
- mechanical lever integrated in the cover
- large separating walls between the contacts guarantees high creeping and leakage distance
- mechanical position indication
- complete accessory
- all relays are 100% computer tested

applications

- switch panel making
- machine and plant industry
- switching between functions

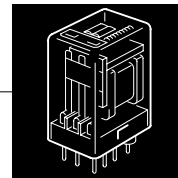

type number key

SFR 143 A 024VDC

coil voltages

024 VAC 024 VDC
 115 VAC 110 VDC
 230 VAC
 (other voltage ranges on enquiry)

option

A = mechanical position indication
 F = free wheel diode
 L = electrical position indication

relay version

SFR 142/082 PCB version
 SFR 143/083 plug-in version
 standard: manual actuation

order samples

manual actuation	position indication	free wheel diode	LED display								
•	•			SFR082 A	VDC/AC	SFR 142 A	VDC/AC	SFR 083 A	VDC/AC	SFR 143 A	VDC/AC
•	•	•		SFR082 AF	VDC	SFR 142 AF	VDC	SFR 083 AF	VDC	SFR 143 AF	VDC
•	•		•	SFR082 AL	VDC/AC	SFR 142 AL	VDC/AC	SFR 083 AL	VDC/AC	SFR 143 AL	VDC/AC
•	•	•	•	SFR082 AFL	VDC	SFR 142 AFL	VDC	SFR 083 AFL	VDC	SFR 143 AFL	VDC



SFR - Industry relay, 4-pole

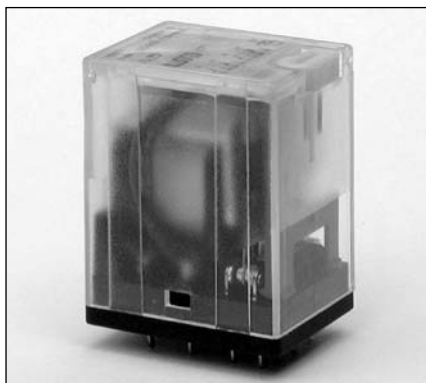

number of contacts **4 WK**
 switching current range **50 mA to 5 A**
 inrush current **15 A**
 specialities **mechanical position indication**
mechanical actuation with lever

order numbers

SFR 143 A ..VDC/AC

contact specifications

contact material	AgCuNi
contact type	single contact
nominal switching capacity	250 VAC 5 A AC1 1250 VA 440 VAC 4 A AC1
electric life expectancy	app. 200'000 operations 250 VAC, 5 A, AC1 (360 operations/h)
max. inrush current	15 A for 20 ms
switching current range	50 mA to 5 A
switching power range	0,3 VA to 1760 VA

option

electrical position indication
 SFR 143 AL ..VDC/AC

general data

mechanic life expectancy	10 x 10 ⁶ operations
mechanical switching frequency	20 Hz
pull-in time	8 ms at DC / 3-9 ms at AC
release time	3,5 ms at DC / 4-12 ms at AC
bounce time normally open contact	3,0 ms at DC / 1-8 ms at AC
bounce time break contact	8 ms at DC / 9-16 ms at AC
shock resistance	AK: > 10 g
test voltage, coil/contact	2000 V _{eff}
test voltage, set of contacts/set of contacts	2000 V _{eff}
test voltage, open contact	1000 V _{eff}
insulation resistance	250 MΩ
creeping resistance	CTI 250
weight	app. 34 g
installation situation	any
ambient temperature	-40 to +70 °C
protection standard	IP 40

accessories

screw socket ES15/4N

tests, instructions

certificates	VDE
insulation group	VDE 0110 / group C 250 VAC

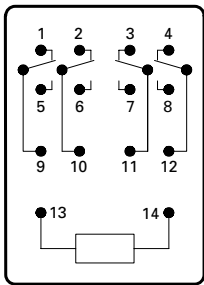
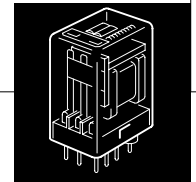

circuit diagram

dimensions

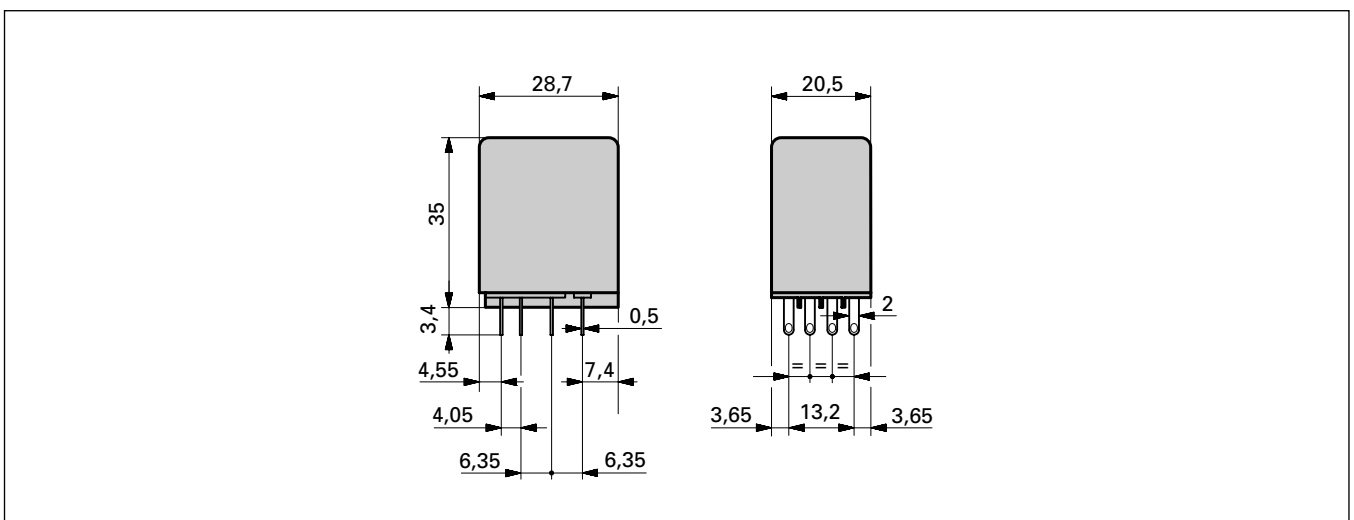

coil specifications

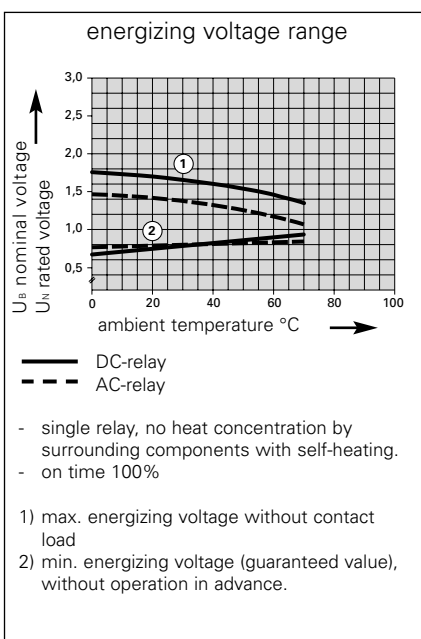

standard coils for direct current (other voltages on enquiry)

rated voltage VDC	pull-in voltage at 20 °C	reset voltage at 20 °C	nominal current mA	resistance Ohm at 20 °C	tolerance %
12	9,0	≥ 0,6	70,60	170	+/-10
24	18,0	≥ 1,2	37,21	645	+/-10
48	36,0	≥ 2,4	18,46	2'600	+/-10
110	82,5	≥ 5,5	8,33	13'200	+/-15

standard coils for alternated current (other voltages on enquiry)

VAC					
12	9,0	≥ 1,8	105,3	39	+/-10
24	18,0	≥ 3,6	51,6	165	+/-10
48	36,0	≥ 7,2	26,0	650	+/-10
110	82,5	≥ 16,5	12,9	3'500	+/-10
230	172,5	≥ 34,5	5,9	15'000	+/-15



SFR - industry relay, 2-pole



number of contacts **2 WK**
switching current range **50 mA to 5 A**
inrush current **15 A**
specialities **mechanical position indication**
mechanical actuation with lever

order numbers

SFR 083 A ..VDC/AC

contact specifications

contact material	AgCuNi
contact type	single contact
nominal switching capacity	250 VAC 5 A AC1 1250 VA 440 VAC 4 A AC1
electric life expectancy	app. 200'000 operations 250 VAC, 5 A, AC1 (360 operations/h)
max. inrush current	15 A for 20 ms
switching current range	50 mA to 5 A
switching power range	0,3 VA to 1760 VA

options

electrical position indication
SFR 083 AL ..VDC/AC

general data

mechanic life expectancy	10 x 10 ⁶ operations
mechanical switching frequency	20 Hz
pull-in time	8 ms at DC / 3-9 ms at AC
release time	3,5 ms at DC / 4-12 ms at AC
bounce time normally open contact	3,0 ms at DC / 1-8 ms at AC
bounce time break contact	8 ms at DC / 9-16 ms at AC
shock resistance	AK: > 10 g
test voltage, coil/contact	2000 V _{eff}
test voltage, set of contacts/set of contacts	2000 V _{eff}
test voltage, open contact	1000 V _{eff}
insulation resistance	250 MΩ
creeping resistance	CTI 250
weight	app. 34 g
installation situation	any
ambient temperature	-40 to +70 °C
protection standard	IP 40

accessories

screw socket ES15/2

tests, instructions

certificates	VDE
insulations group	VDE 0110 / group C 250 VAC

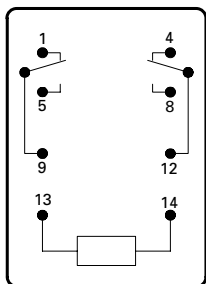
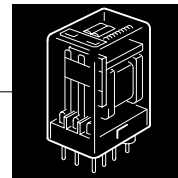

circuit diagram

dimensions

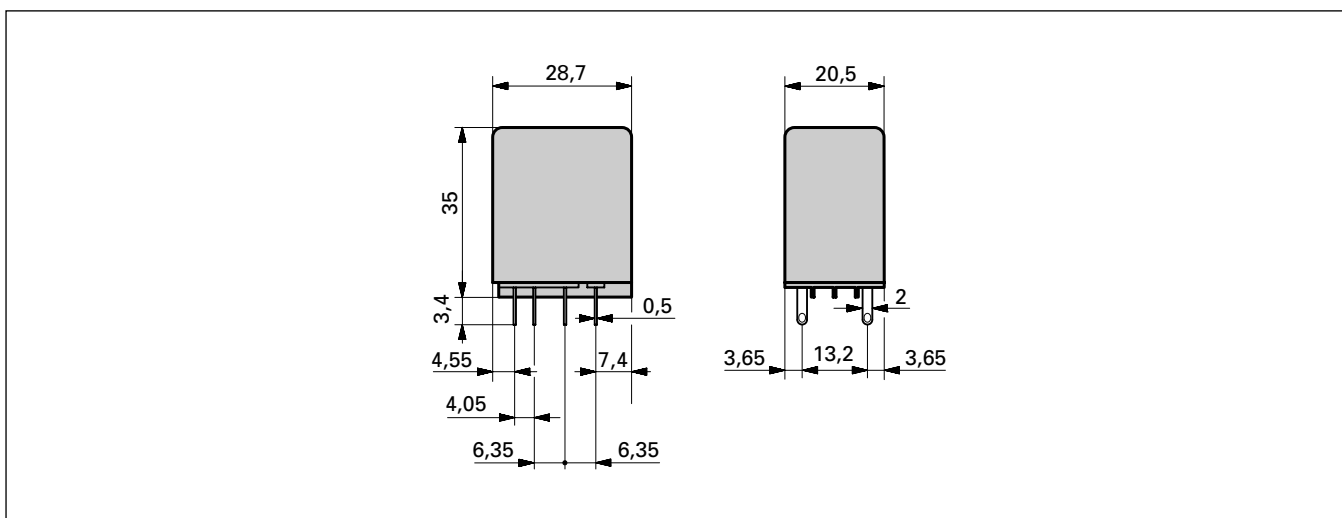

coil specifications

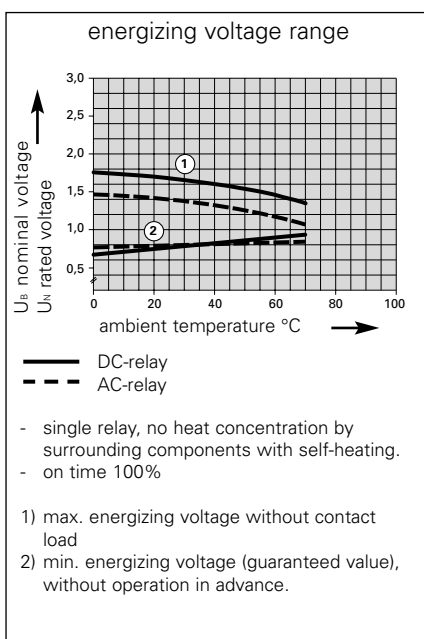

standard coils for direct current (other voltages on enquiry)

rated voltage VDC	pull-in voltage at 20 °C	reset voltage at 20 °C	nominal current mA	resistance Ohm at 20 °C	tolerance %
12	9,0	≥ 0,6	70,60	170	+/-10
24	18,0	≥ 1,2	37,21	645	+/-10
48	36,0	≥ 2,4	18,46	2'600	+/-10
110	82,5	≥ 5,5	8,33	13'200	+/-15

standard coils for alternated current (other voltages on enquiry)

VAC					
12	9,0	≥ 1,8	105,3	39	+/-10
24	18,0	≥ 3,6	51,6	165	+/-10
48	36,0	≥ 7,2	26,0	650	+/-10
110	82,5	≥ 16,5	12,9	3'500	+/-10
230	172,5	≥ 34,5	5,9	15'000	+/-15



SFR - industry relay, PCB version



number of contacts **4 WK**
 switching current range **50 mA bis 5 A**
 inrush current **15 A**
 specialities **mechanical position indication**
mechanical actuation with lever

order numbers

SFR 142 A ..VDC/AC

contact specifications

contact material	AgCuNi
contact type	single contact
nominal switching capacity	250 VAC 5 A AC1 1250 VA 440 VAC 4 A AC1
electric life expectancy	app. 200'000 operations 250 VAC, 5 A, AC1 (360 operations/h)
max. inrush current	15 A for 20 ms
switching current range	50 mA to 5 A
switching power range	0,3 VA to 1760 VA

options

electrical position indication
 SFR 142 AL ..VDC/AC

general data

mechanic life expectancy	10 x 10 ⁶ operations
mechanical switching frequency	20 Hz
pull-in time	8 ms at DC / 3-9 ms at AC
release time	3,5 ms at DC / 4-12 ms at AC
bounce time normally open contact	3,0 ms at DC / 1-8 ms at AC
bounce time break contact	8 ms at DC / 9-16 ms at AC
shock resistance	AK: > 10 g
test voltage, coil/contact	2000 V _{eff}
test voltage, set of contacts/set of contacts	2000 V _{eff}
test voltage, open contact	1000 V _{eff}
insulation resistance	250 MΩ
creeping resistance	CTI 250
weight	app. 34 g
installation situation	any
ambient temperature	-40 to +70 °C
protection standard	IP 40

tests, instructions

certificates	VDE
insulations group	VDE 0110 / group C 250 VAC

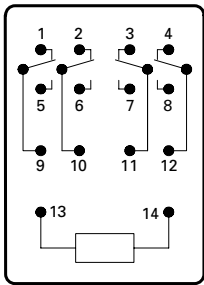
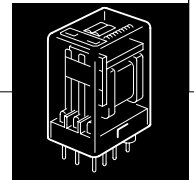

circuit diagram

dimensions

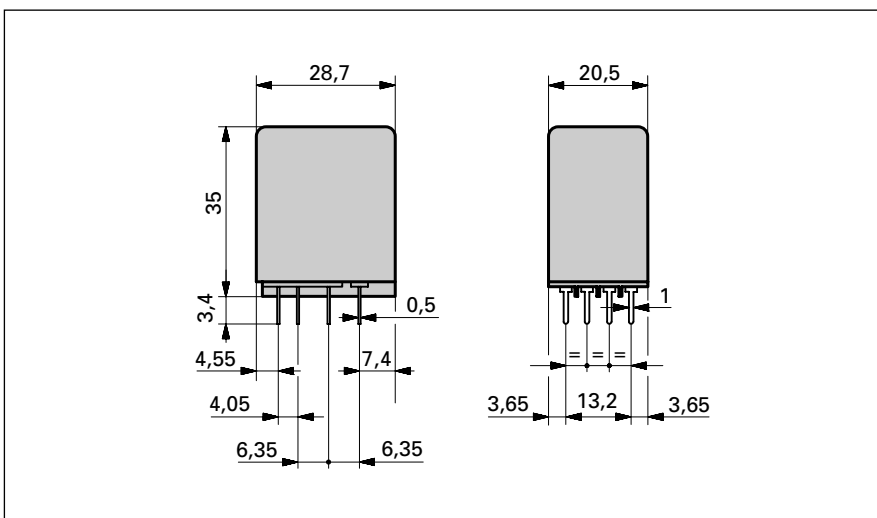

drilling plan

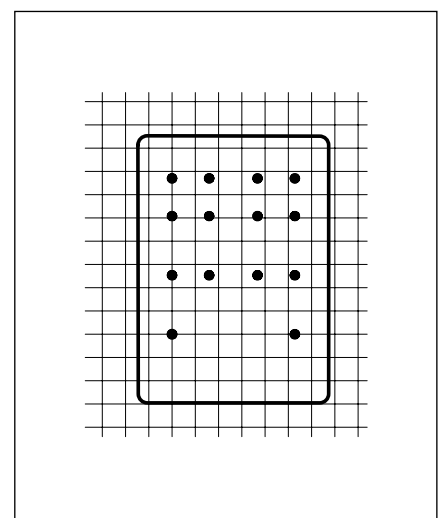

coil specifications

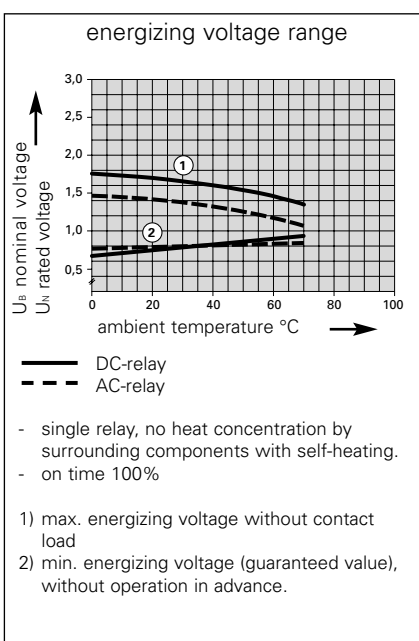

standard coils for direct current (other voltages on enquiry)

rated voltage VDC	pull-in voltage at 20 °C	reset voltage at 20 °C	nominal current mA	resistance Ohm at 20 °C	tolerance %
12	9,0	≥ 0,6	70,60	170	+/-10
24	18,0	≥ 1,2	37,21	645	+/-10
48	36,0	≥ 2,4	18,46	2'600	+/-10
110	82,5	≥ 5,5	8,33	13'200	+/-15

standard coils for alternated current (other voltages on enquiry)

VAC	pull-in voltage at 20 °C	reset voltage at 20 °C	nominal current mA	resistance Ohm at 20 °C	tolerance %
12	9,0	≥ 1,8	105,3	39	+/-10
24	18,0	≥ 3,6	51,6	165	+/-10
48	36,0	≥ 7,2	26,0	650	+/-10
110	82,5	≥ 16,5	12,9	3'500	+/-10
230	172,5	≥ 34,5	5,9	15'000	+/-15



SFR - industry relay, PCB version



number of contacts **2 WK**
switching current range **50 mA bis 5 A**
inrush current **15 A**
specialities **mechanical position indication**
mechanical actuation with lever

order numbers

SFR 082 A ..VDC/AC

contact specifications

contact material	AgCuNi
contact type	single contact
nominal switching capacity	250 VAC 5 A AC1 1250 VA 440 VAC 4 A AC1
electric life expectancy	app. 200'000 operations 250 VAC, 5 A, AC1 (360 operations/h)
max. inrush current	15 A for 20 ms
switching current range	50 mA to 5 A
switching power range	0,3 VA to 1760 VA

options

electrical position indication
SFR 082 AL ..VDC/AC

general data

mechanic life expectancy	10 x 10 ⁶ operations
mechanical switching frequency	20 Hz
pull-in time	8 ms at DC / 3-9 ms at AC
release time	3,5 ms at DC / 4-12 ms at AC
bounce time normally open contact	3,0 ms at DC / 1-8 ms at AC
bounce time break contact	8 ms at DC / 9-16 ms at AC
shock resistance	AK: > 10 g
test voltage, coil/contact	2000 V _{eff}
test voltage, set of contacts/set of contacts	2000 V _{eff}
test voltage, open contact	1000 V _{eff}
insulation resistance	250 MΩ
creeping resistance	CTI 250
weight	app. 34 g
installation situation	any
ambient temperature	-40 to +70 °C
protection standard	IP 40

tests, instructions

certificates	VDE
insulations group	VDE 0110 / group C 250 VAC

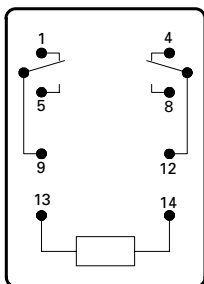
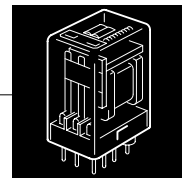

circuit diagram

dimensions

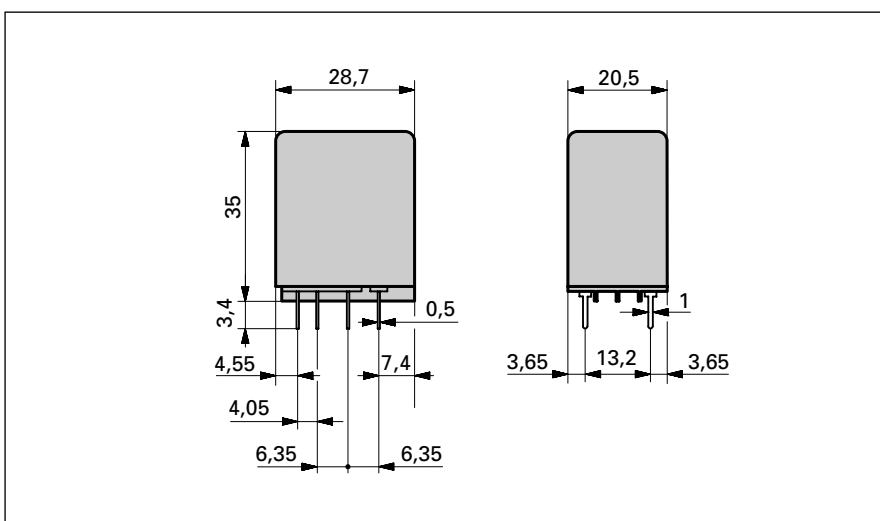

drilling plan

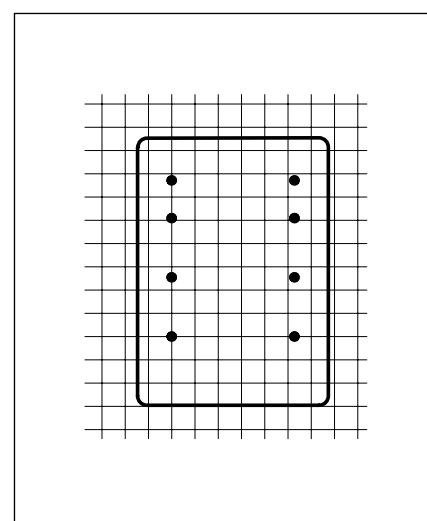

coil specifications

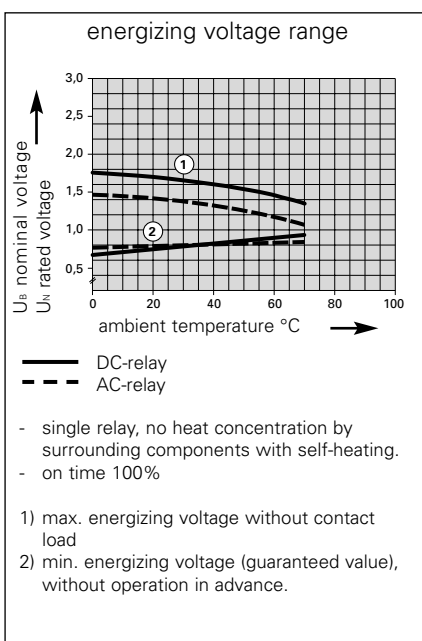

standard coils for direct current (other voltages on enquiry)

rated voltage VDC	pull-in voltage at 20 °C	reset voltage at 20 °C	nominal current mA	resistance Ohm at 20 °C	tolerance %
12	9,0	≥ 0,6	70,60	170	+/-10
24	18,0	≥ 1,2	37,21	645	+/-10
48	36,0	≥ 2,4	18,46	2'600	+/-10
110	82,5	≥ 5,5	8,33	13'200	+/-15

standard coils for alternated current (other voltages on enquiry)

VAC	pull-in voltage at 20 °C	reset voltage at 20 °C	nominal current mA	resistance Ohm at 20 °C	tolerance %
12	9,0	≥ 1,8	105,3	39	+/-10
24	18,0	≥ 3,6	51,6	165	+/-10
48	36,0	≥ 7,2	26,0	650	+/-10
110	82,5	≥ 16,5	12,9	3'500	+/-10
230	172,5	≥ 34,5	5,9	15'000	+/-15



SFR - contact specifications

AgCuNi single contact

load limit curve for DC resistive load

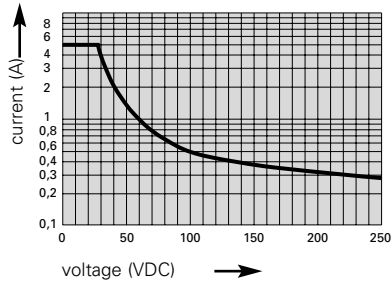

contact life time

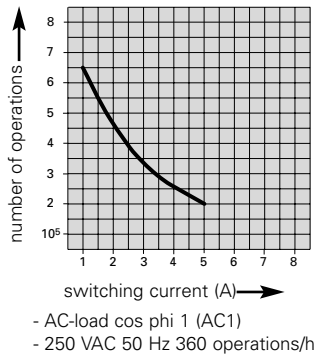

data valid for relay	SFR 143
contact material	AgCuNi (Ag1,88 Ni0,12)
contact type	single contact
nominal switching capacity	250 VAC 5 A AC1 1250 VA 440 VAC 4 A AC1
electric life expectancy	app. 200'000 operations 250 VAC 5 A AC1 (360 operations/h)
inrush current max.	15 A for 20 ms
switching current range	50 mA to 5 A
switching power range	0,3 VA to 2500 VA
contact resistance	20 mΩ

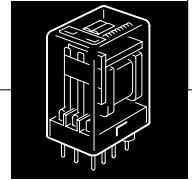

socket

ES15/4N

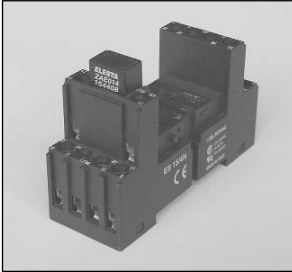

data

nominal data		300 VAC 12 A
dimensions (L x B x H)	[mm]	66 x 29,5 x 29
ambient temperature	[°C]	-40 to +85

accessories

plug-in modules	E...
metal clamp	Clip MHO
plastic clamp	Clip MS35

plug-in modules

E...

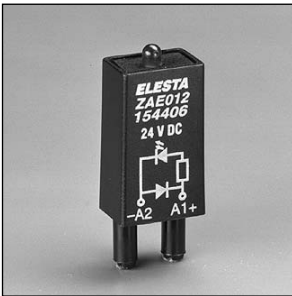

data

compatible to socket		ES15/4N
free wheel diode	230 VDC	E22
RC-circuit	240 VAC	E52C
LED	24 - 60 VAC/DC	E62EV
LED	110 - 230 VAC/DC	E92V

